

ASP-coat500 Flake | 0.8mm

ASP-coat500 Flake is a decorative, solvent-free, easily applied high-build epoxy floor coating, designed to protect concrete substrates.

ASP-coat500 Flake is best suited to coat floors in light to medium traffic areas where a hard-wearing, decorative floor finish is required.

BENEFITS



Excellent resistance to cleaning solvents and various other industrial chemicals



Solvent-free and low odour formulation



Slip resistance profile may be customised



Hygienic, easy to clean, non-tainting and non-dusting coating



Decorative, aesthetic coating

APPLICATIONS

- Retail showrooms
- Laboratories
- Offices
- Hospitals, canteens and schools
- Pharmaceutical and cosmetic industry

SYSTEM INFORMATION

Coving Components

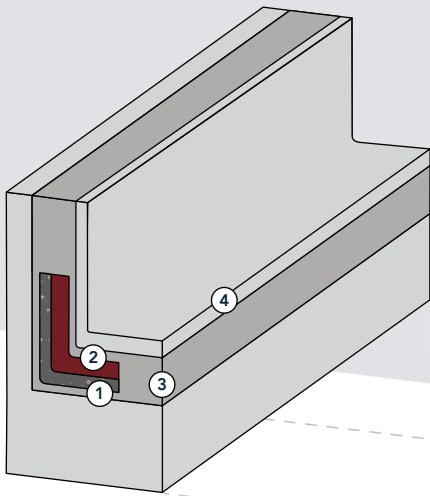

Flooring Components

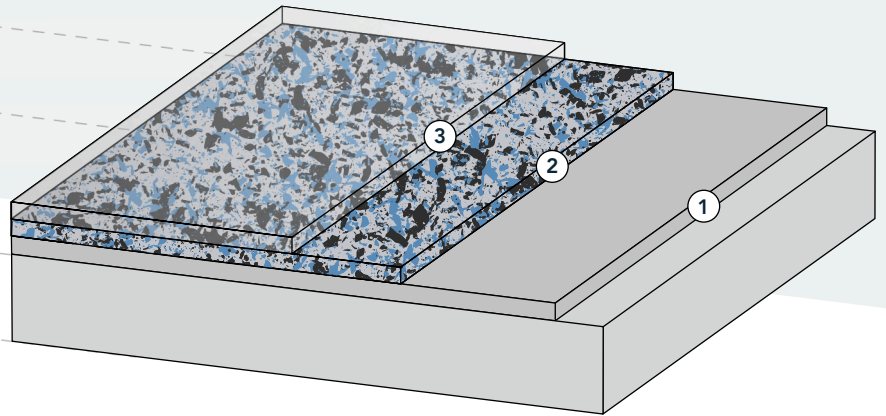

- 1 Primer and Scatter Sand**
 · ASP-primeStd 4m²/litre · ASP-Quartz 1 1kg/m²

- 2 Coving**
 · ASP-epoxyCove 1.8 litre/linear meter (75mm x 75mm)

- 3 Primer**
 · ASP-primeStd 4m²/litre

- 4 Coating**
 (Uni-Colour or Flakes Options)
 · ASP-coat500 4m²/litre

- 1 Primer**
 · ASP-primeStd 4m²/litre

- 2 Base Coating and Flakes**
 · ASP-coat500 2m²/litre
 · ASP-Flakes 400g/m²

- 3 Coating**
 · ASP-clearCoat 3m²/litre

PRODUCT INFORMATION

PRODUCT CHARACTERISTICS	RESULT
Appearance	Gloss
Standard Colours*	 Basset  Cam  Cain Fever  Domino
Theoretical Coverage (ASP-coat500)	2m ² /litre

Theoretical Coverage / 20l Kit	40m ²
Theoretical Coverage (Flakes)	400g/m ²
Theoretical Coverage / 5kg	12.5m ²
Storage	Keep at an ambient temperature in dry, cold-free conditions
Shelf Life	12 months in unopened original packaging

*Non-standard colours are available at a premium on request of a minimum order quantity.

TECHNICAL INFORMATION

PERFORMANCE CRITERIA	RESULT	
Fire Resistance	Class 4 - SANS 10177 - 4 : 2005	
Compressive Strength	SABS SM 863:1994	>70 N/mm ²
Flexural Strength	SABS SM 864:1994	>25 N/mm ²
Tensile Strength	SABS SM 1253:1994	>15 N/mm ²
Impact Resistance	ISO 6272-1:2011	1kg weight >1.8m 2kg weight >1.5m
Chemical Resistance	Resistant to a very wide range of chemicals. For a full chemical resistance breakdown, contact our Sales or Technical Services Team.	
Working Time	15 – 20 minutes @ 20°C	
Speed of Cure @20°C	Light Foot Traffic – 16 hours	Heavy Duty Traffic – 48 hours
	Light Traffic – 24 hours	Full Chemical Cure – 7 days

SUBSTRATE AND PREPARATION REQUIREMENTS

Concrete substrates to be coated must be sound and exhibit a minimum compressive strength of 25N/mm² and a minimum of 1.5N/mm² tensile strength for the application of the proposed system. The profile and levels must be appropriate for the application of the proposed system, capable of bearing loads, free of cracks and voids, and free from laitance, dust and other contamination. The substrate must be dry to 75% relative humidity and free from rising damp, ground water, oil and other contamination. Should there be rising damp, ground water problems or impurities such as penetrated oils, etc., please refer to the ASP Technical Team for a suitable and appropriate substrate preparation guideline or solution. The substrate may be prepared by diamond grinding or shot blasting to remove laitance. Irregularities, small damages and cracks must be repaired with an epoxy filler.

APPLICATION

PRIMER

Mix Base A and Hardener B with a low-speed drill fitted with a spiral mixing blade for approximately 3 minutes to obtain a homogeneous mixture. Ensure excessive air is not introduced while mixing. The mixed material must be applied within 15 minutes at 20°C. Apply immediately after mixing with a white short-haired white roller or double-lipped rubber squeegee, working the resin well into the substrate, permeating any surface irregularities. On porous substrates, apply further resin until the substrate is completely wetted out. Avoid any ponding of the primer.

BASE COAT

Mix Base A and Hardener B together with a low-speed drill fitted with a spiral mixing blade for approximately 3 minutes to obtain a homogeneous mixture. Ensure excessive air is not introduced while mixing. The mixed material must be applied within 15 - 20 minutes at 20°C.

Apply immediately after mixing with a 1.2mm precision coating rake. Roll with a bubble buster/spike roller to release any trapped air. Broadcast the flakes onto the wet epoxy. Allow to cure overnight. De-nib with a new steel flat trowel. Sweep, blow and then vacuum any excess flakes.

TOP COAT

Mix Base A and Hardener B with a low-speed drill fitted with a spiral mixing blade for approximately 3 minutes to obtain a homogeneous mixture. Ensure excessive air is not introduced while mixing. The mixed material must be applied within 15 minutes at 20°C. Apply immediately after mixing with a double-lipped rubber squeegee, followed by a short-hair roller, working the resin well into the coating, permeating any surface irregularities.

For more detailed information on substrate requirements and preparation, priming and application of the top coat, please refer to the product's method statement.

CLEANING OF TOOLS AND EQUIPMENT

All tools, equipment and mixing vessels may be immediately cleaned with a suitable water soluble solvent, epoxy thinners or acetone. Ensure that all washings are disposed of in accordance with the local environmental, health and safety by-laws.

MAINTENANCE

It is recommended that all spillages onto the ASP-coat500 Flake be cleaned immediately to maintain the appearance and lifespan of the coating. ASP-coat500 Flake must be regularly cleaned with a rotary brush or mechanical scrubbers using a suitable detergent.

ENVIRONMENTAL, HEALTH AND SAFETY REQUIREMENTS

Applicators must ensure the use of appropriate personal protective equipment when working with the product. All used and empty packaging, used solvents and washings must be disposed of in accordance with the local environmental, health and safety by-laws. Please refer to the product's material safety data sheet for more detailed information.

LEGAL NOTICE

African Specialist Polymers' systems and products are guaranteed against defective material and manufacture and are sold subject to its Standard Terms and Conditions of Sale, copies of which can be obtained on request.

The information and the recommendations relating to the application and end-use of African Specialist Polymers' products are given in good faith, based on African Specialist Polymers' current knowledge and experience of the products when stored, handled and applied in accordance with African Specialist Polymers' recommendations.

The information herein is of a general nature and as such no assumption can be made about a product's suitability for a particular use or application and no warranty as to its accuracy, reliability or completeness either expressed or implied is given other than those required by law. The user is responsible for checking the suitability of the selected products for their intended use.