



ASP-creteMD | 3.5 – 4.0mm

ASP-creteMD is a HACCP certified medium duty, easily applied, self-smoothing polyurethane concrete screed offering excellent chemical and wear resistance in food and beverage processing facilities.

ASP-creteMD is best suited to use in dry and semi-wet food processing and preparation areas subject to high temperature swings, chemical spillage and medium duty traffic.

BENEFITS



HACCP certified



Excellent resistance to corrosive foodstuffs and most aggressive cleaning solvents



Thermal range of -15°C to 70°C at a minimum of 3.5mm



Fast return to service in refurbishment scenarios



Excellent cleanability and seamless hygienic finish



Food safe, solvent-free, odourless, non-tainting and non-dusting

APPLICATIONS

- Food and beverage production, processing and preparation
- Catering kitchens
- Dairy and cheese production
- Dry processing packing halls
- Distribution centres and warehousing
- Laboratories

SYSTEM INFORMATION

Coving Components

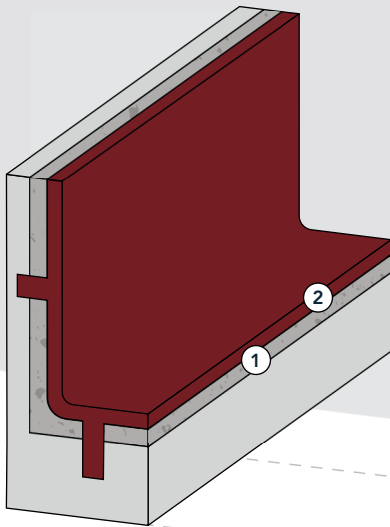

Flooring Components

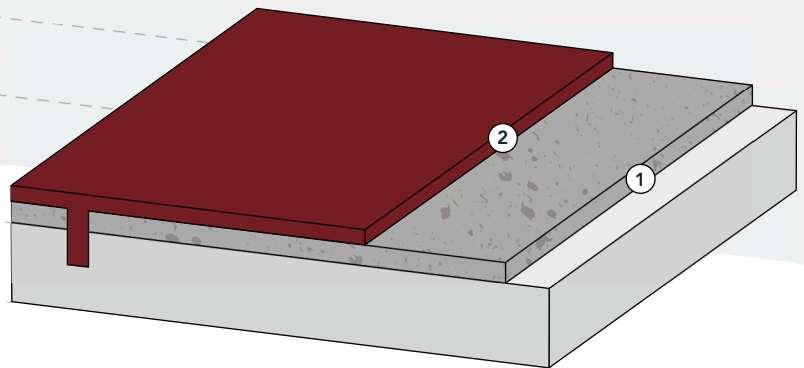

1

Primer & Scatter Sand

- ASP-primeStd
4m²/litre
- ASP-Quartz 1
1kg/m²

2

Coving

- ASP-creteVS
1.8 litre/linear metre
(75mm x 75mm)
- ASP-creteCoat (optional)
2m²/litre (2 coats)

1

Primer & Scatter Sand











- ASP-primeStd
4m²/litre
- ASP-Quartz 3
1kg/m²

2

Coating

- ASP-creteMD
3.5 - 4.0 litre/m²

PRODUCT INFORMATION

PRODUCT CHARACTERISTICS	RESULT
Appearance	Pigmented Matt
Standard Colours*	      Grey RAL 7004 Dark Grey RAL 7012 Black Grey RAL 7021 Beige RAL 1001 Yellow Ochre Red RAL 3011
Non-standard Colours**	    Sand Yellow RAL 1002 Dark Blue RAL 5019 Green RAL 6011 Signal Red RAL 3001
Theoretical Coverage	3.5 – 4.0 litre/m ²
Theoretical Coverage / 18.2l Kit	5.2m ² @ 3.5mm or 4.5m ² @ 4mm
Shelf Life	12 months from date of manufacture in unopened original packaging
Storage	Keep at an ambient 10 – 25°C temperature in dry, cold-free conditions

*RAL Numbers are only indicative of a reference of colour.

**Non-standard colours are available at a premium on request of a minimum order quantity.

TECHNICAL INFORMATION

PERFORMANCE CRITERIA	RESULT	
Temperature Resistance	Thermal range: -15°C to 70°C at a minimum of 3.5mm	
Slip Resistance	BS 7976-2: Pendulum Slip Test	≥ 60 dry
Chemical Resistance	Resistant to a wide range of aggressive chemicals and corrosive by-products. For a full chemical resistance breakdown, contact our Sales or Technical Services Team.	
Compressive Strength	SABS 865:1994	>50 MPa
Flexural Strength	SANS 5864:2006	12 MPa
Tensile Strength	SANS 6253:2006	6 MPa
Bond Strength	Greater than cohesive strength of 25N/mm ² concrete >1.5N/mm ²	
Surface Hardness	Schmidt Hammer ASTM C805	40 MPa
Water Permeability	Karsten Test	Nil (Impermeable)
Working Time	10-15 minutes @ 20°C	
Speed of Cure @20°C	Light Traffic – 24 hours	Full Chemical Cure – 7 days
	Heavy Duty Traffic – 48 hours	

SUBSTRATE AND PREPARATION REQUIREMENTS

Concrete substrates to be coated must be sound and exhibit a minimum compressive strength of 25N/mm² and a minimum of 1.5N/mm² tensile strength for the application of the proposed system. The profile and levels must be appropriate for the application of the proposed system, capable of bearing loads, free of cracks and voids, and free from laitance, dust and other contamination.

The substrate must be dry to 75% relative humidity and free from rising damp, ground water, oil and other contamination. Should there be rising damp, ground water problems or impurities such as penetrated oils, etc., please refer to the ASP Technical Team for a suitable and appropriate substrate preparation guideline or solution. The substrate may be prepared by blasting or diamond grinding to remove laitance. Irregularities, small damages and cracks must be repaired with an epoxy filler.

Before application of the flooring system, anchor grooves must be cut approximately 4mm deep x 4mm wide and 25mm on either side of the expansion joints, saw cuts and floor edges.

APPLICATION

PRIMER

Mix Base A and Hardener B with a low speed drill fitted with a spiral mixing blade for approximately 3 minutes to obtain a homogeneous mixture. Ensure air is not introduced while mixing. The mixed material must be applied within 15 minutes at 20°C. Apply immediately after mixing with a roller or double lipped rubber squeegee, working the resin well into the substrate, permeating any surface irregularities. On porous substrates apply further resin until the substrate is completely wetted out. Avoid any ponding of the primer. Broadcast into the wet primer with the appropriate size scatter sand at 1kg/m². When cured, sweep off or vacuum the loose scatter sand.

TOPCOAT

Mix Base A and Hardener B together in a rotatory pan mixer or with a low speed drill fitted with a spiral mixing blade for approximately 2 minutes. Slowly add the pigment pack and mix for a further 1 minute to obtain a homogeneous mixture. Finally, add in the Filler C and mix for an additional 2 minutes. Ensure air is not introduced while mixing. The mixed material must be applied within 10 - 15 minutes at 20°C. Apply immediately after mixing with a 10mm precision coating rake. Allow to stand for approximately 5 minutes, then roll in one direction with a bubble buster / spike roller to release any trapped air.

For more detailed information on substrate requirements and preparation, priming and application of the top coat, please refer to the product's method statement.

CLEANING OF TOOLS AND EQUIPMENT

All tools, equipment and mixing vessels may be immediately cleaned with a suitable water soluble solvent, epoxy thinners or acetone. Ensure that all washings are disposed of in accordance with the local environmental, health and safety by-laws.

MAINTENANCE

It is recommended that all spillages onto the ASP-creteMD be cleaned immediately to maintain the appearance and life span of the coating. ASP-creteMD must be regularly cleaned with a rotary brush or mechanical scrubbers using a suitable detergent.

ENVIRONMENTAL, HEALTH AND SAFETY REQUIREMENTS

Applicators must ensure the use of appropriate personal protective equipment when working with the product. All used and empty packaging, used solvents and washings must be disposed of in accordance with the local environmental, health and safety by-laws. Please refer to the product's material safety data sheet for more detailed information.

LEGAL NOTICE

African Specialist Polymers' systems and products are guaranteed against defective material and manufacture and are sold subject to its Standard Terms and Conditions of Sale, copies of which can be obtained on request.

The information and the recommendations relating to the application and end-use of African Specialist Polymers' products are given in good faith, based on African Specialist Polymers' current knowledge and experience of the products when stored, handled and applied in accordance with African Specialist Polymers' recommendations.

The information herein is of a general nature and as such no assumption can be made about a product's suitability for a particular use or application and no warranty as to its accuracy, reliability or completeness either expressed or implied is given other than those required by law. The user is responsible for checking the suitability of the selected products for their intended use.